

TOP VIEW

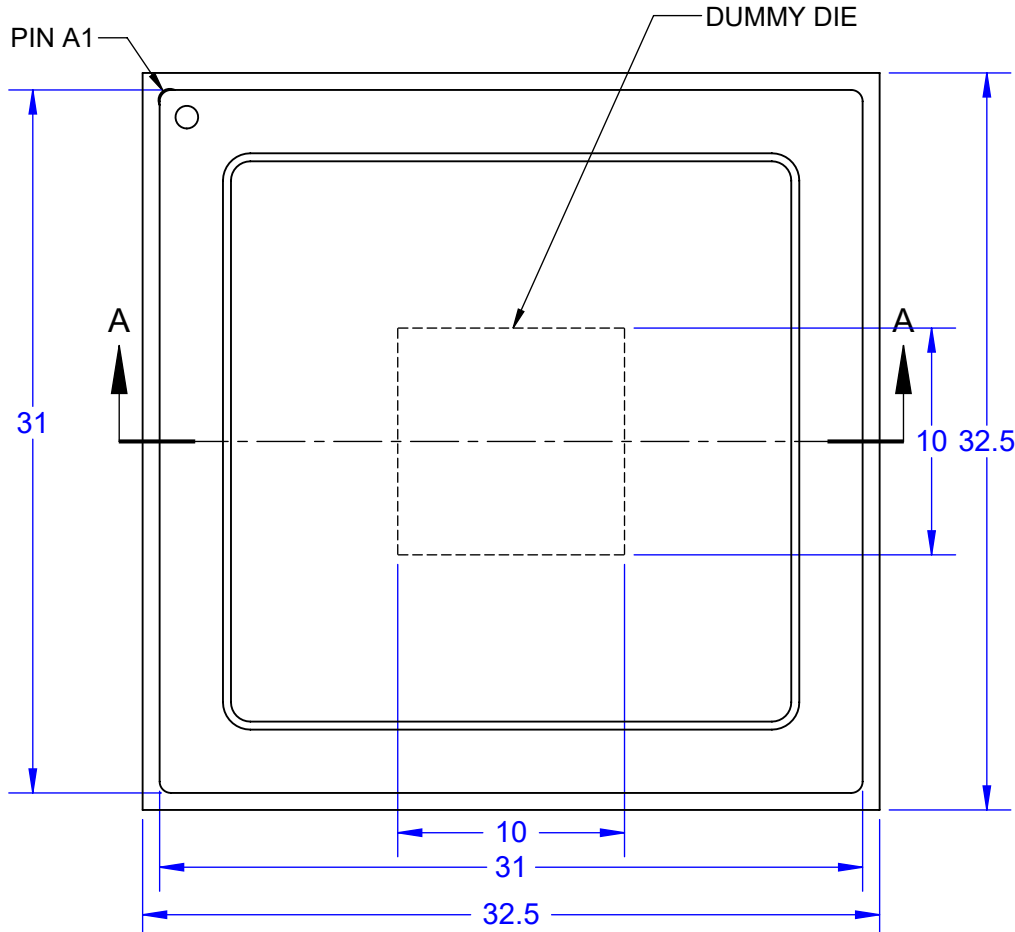

BALL VIEW

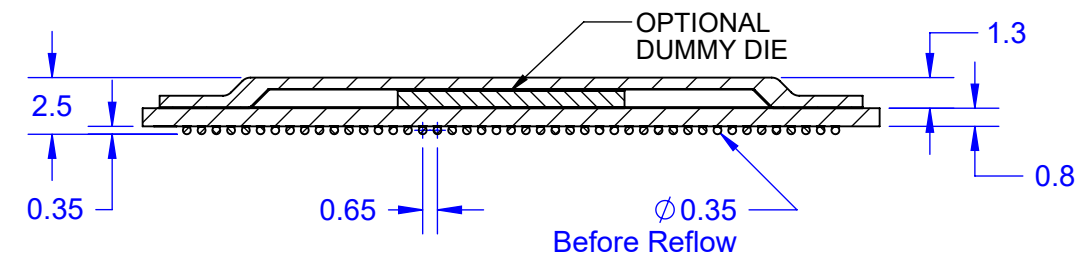
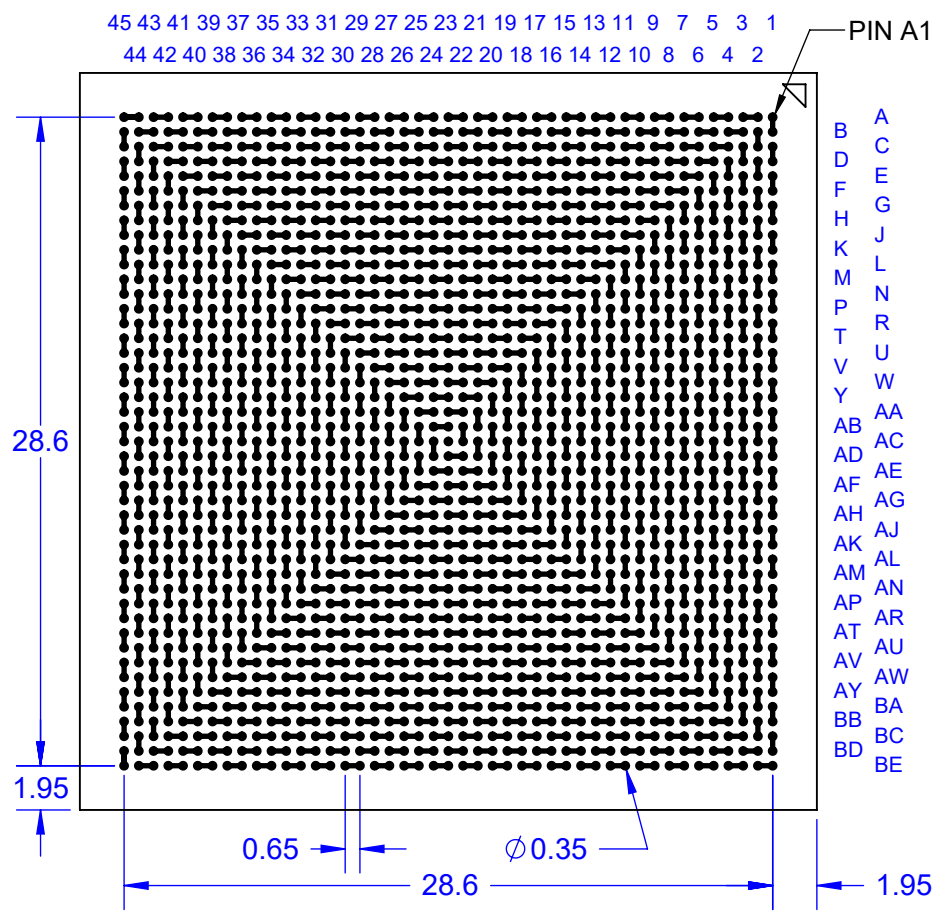

SECTION A-A

Notes: (Unless Otherwise Specified).

- 1) ALL DIMENSIONS ARE IN MM.
- 2) SOLDER BALL ALLOY: SEE PART NUMBER TABLE.
- 3) BALL DIAMETER (BEFORE REFLOW): 0.35mm (13.8 MIL).
- 4) SOLDER MASK DEFINED PAD OPENING: 0.33mm (13 MIL).
- 5) PAD Cu DIAMETER: 0.45mm (18 MIL).
- 6) SUBSTRATE MATERIAL: BT.
- 7) DUMMY DIE IS OPTIONAL.
- 8) DAISY CHAIN PATTERN (SEE PAGE 2).
- 9) MSL-3 RECOMMENDED BAKING 24 HOURS @ 125°C TO REMOVE MOISTURE PRIOR SOLDERING TO PC BOARD.

PART NUMBER TABLE

PART NUMBER	BALL ALLOY	Pb-Free	RoHS	Si DIE
SBGA2025T.65C-DC459D	Sn96.5/Ag3.0/Cu0.5	YES	YES	YES
SBGA2025T.65-DC459D	Sn63/Pb37	NO	NO	YES

APPROVALS	DATE	TopLine®			
DRAWN T.Au	9/21/2024				
ENG M. Hart	9/21/2024	TITLE SBGA2025T.65-DC459D DAISY CHAIN DUMMY			
MFG		SCALE 3:1	SIZE A	DRAWING NO. 564595	REV A
QA		DO NOT SCALE DRAWING			SHEET 1 OF 10
CUST					
REVISED					

BALL VIEW

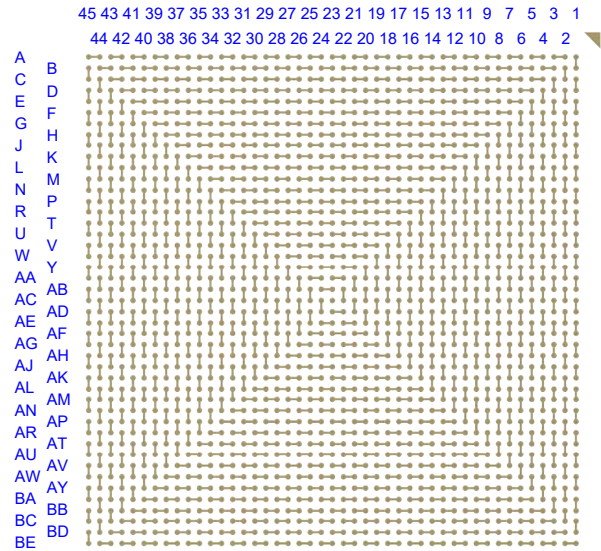

BOTTOM SIDE (TOP X-RAY VIEW)

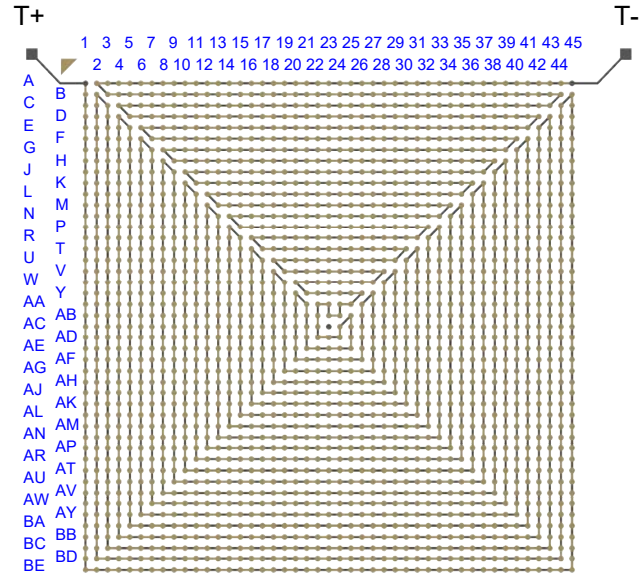
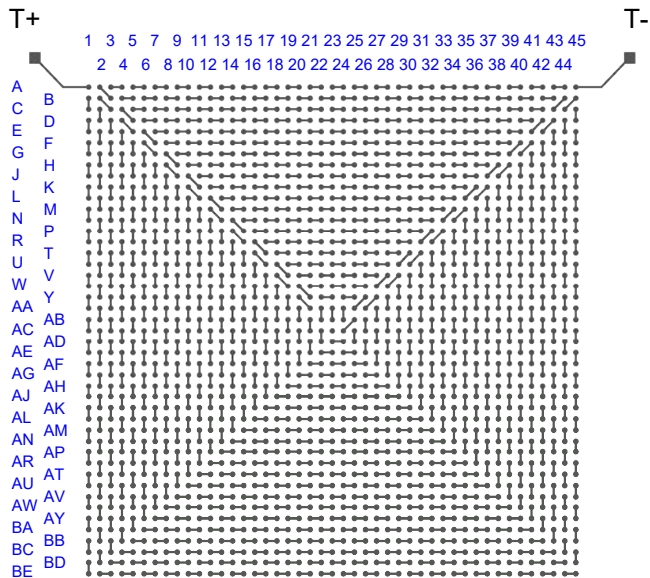
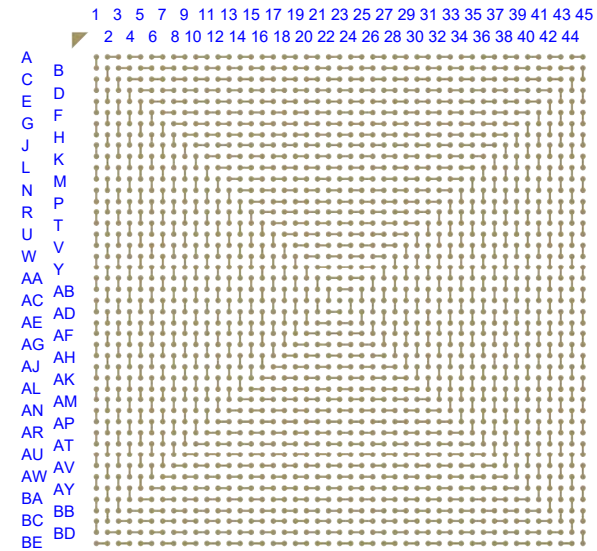

TEST VEHICLE BOARD

AFTER MOUNTING

Notes:

- 1) PCB BOARD DIMENSIONS ARE PRESENTED ONLY AS A GUIDELINE. DESIGNERS SHOULD USE THEIR OWN EXPERIENCE WHEN DESIGNING PCB.
- 2) PCB Cu BALL PAD DIAMETER 0.45mm (18 MIL).
- 3) PCB DAISY CHAIN TRACING LINE WIDTH 0.152mm (6 MIL).
- 4) SMD (SOLDER MASK DEFINED) PAD OPENING: 0.33mm (13 MIL).



TITLE			
SBGA2025T.65-DC459D DAISY CHAIN DUMMY			
SCALE	SIZE	DRAWING NO.	REV
2.25:1	A	564595	A
DO NOT SCALE DRAWING			SHEET 2 OF 10

BALL VIEW

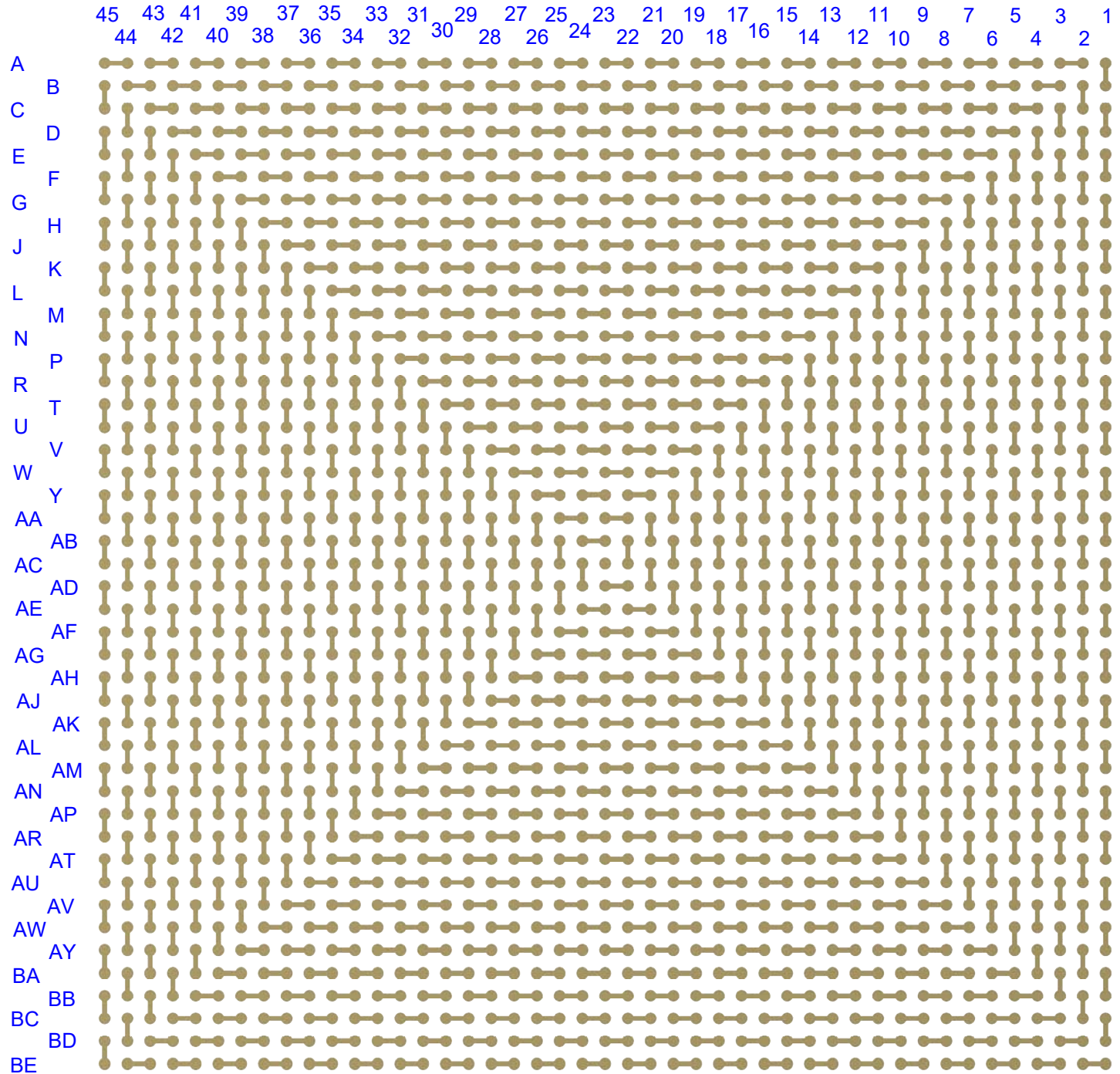

TopLine®			
TITLE		SGBA2025T.65-DC459D DAISY CHAIN DUMMY	
SCALE	SIZE	DRAWING NO.	REV
2.25:1	A	564595	A
DO NOT SCALE DRAWING			SHEET 3 OF 10

BOTTOM SIDE (TOP X-RAY VIEW)

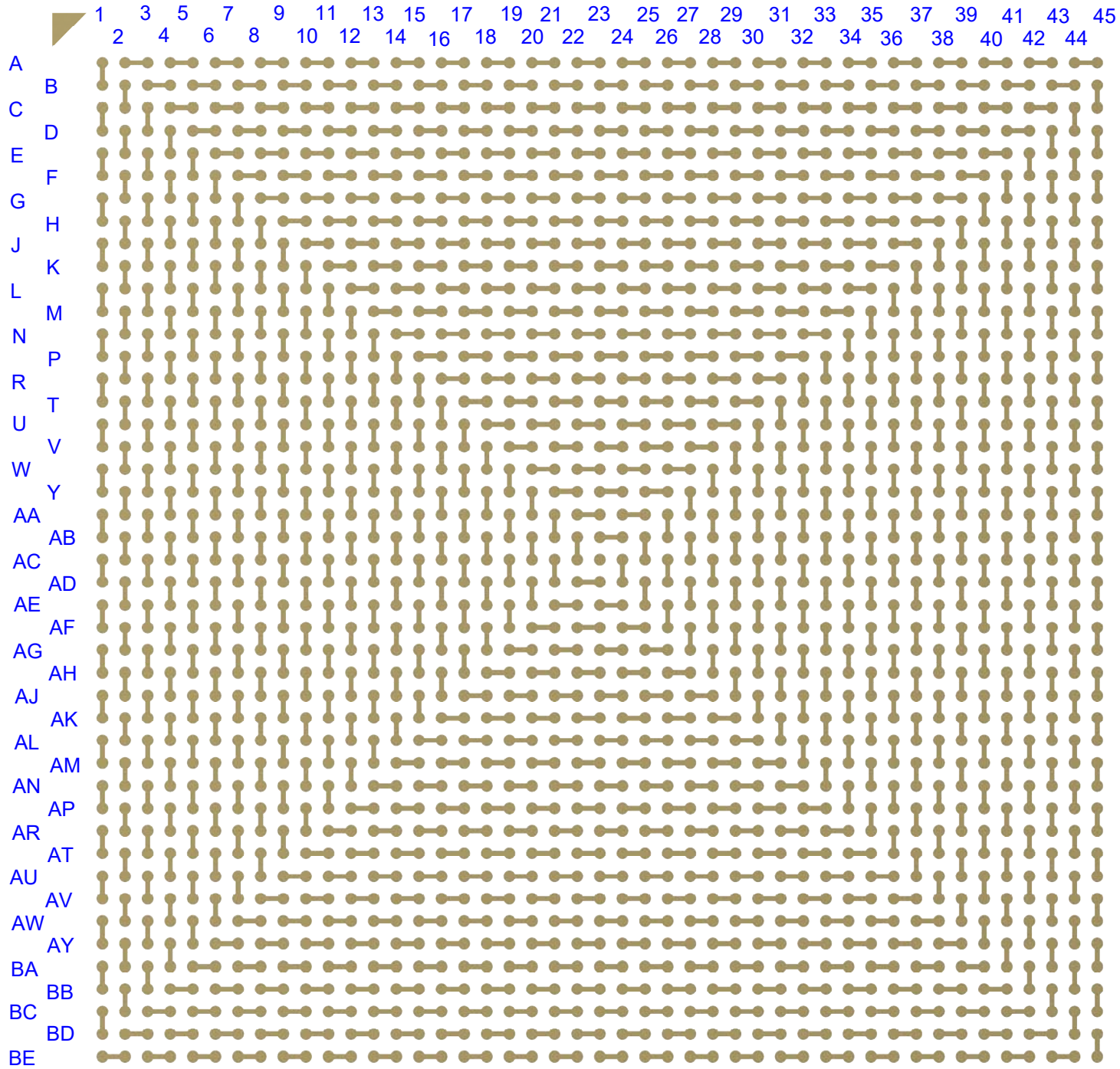

TopLine®			
TITLE		SBSGA2025T.65-DC459D DAISY CHAIN DUMMY	
SCALE	SIZE	DRAWING NO.	REV
2.25:1	A	564595	A
DO NOT SCALE DRAWING			SHEET 4 OF 10

TEST VEHICLE BOARD

T+

T-

1 3 5 7 9 11 13 15 17 19 21 23 25 27 29 31 33 35 37 39 41 43 45
 2 4 6 8 10 12 14 16 18 20 22 24 26 28 30 32 34 36 38 40 42 44

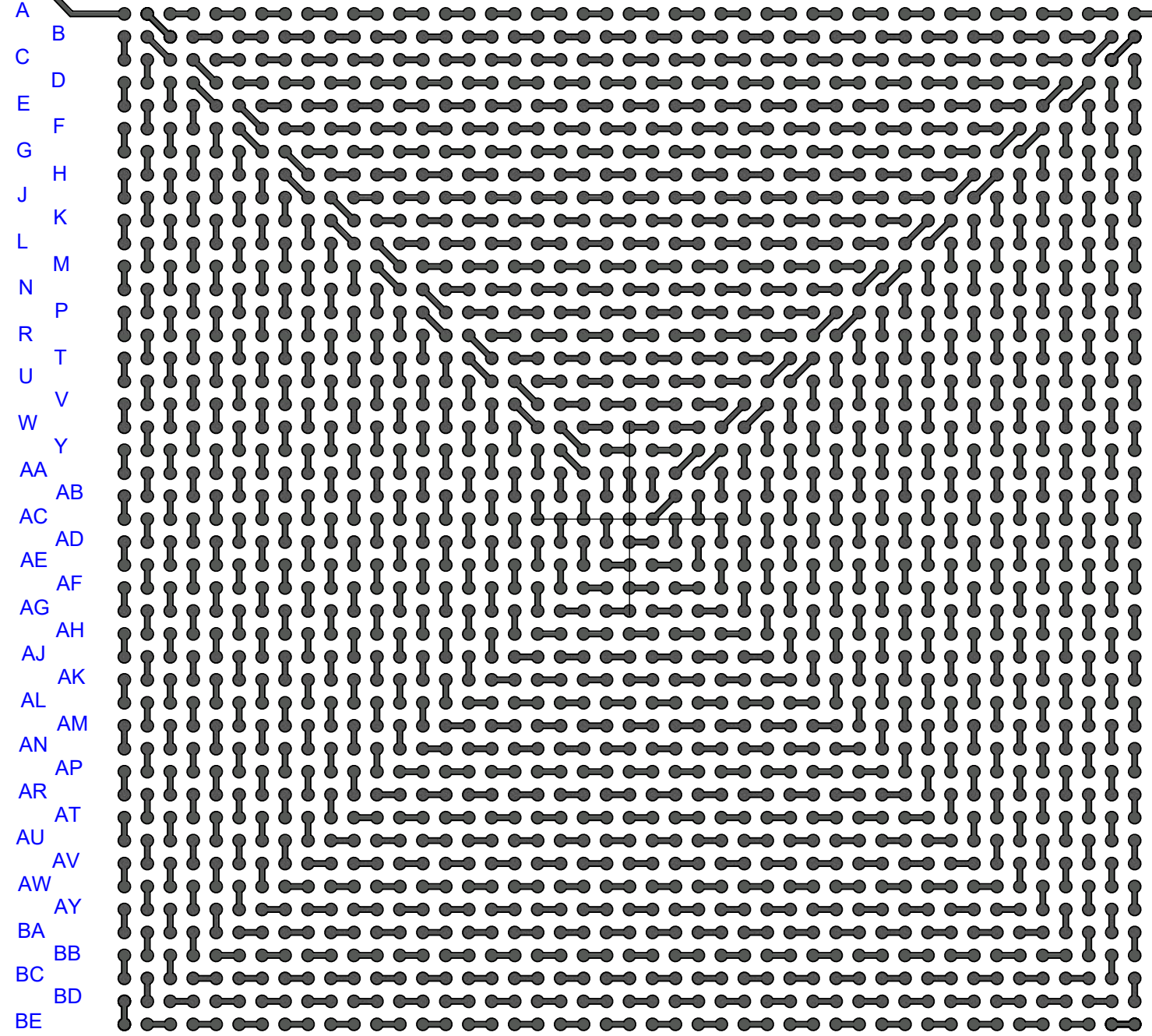

TITLE			
SBGA2025T.65-DC459D DAISY CHAIN DUMMY			
SCALE	SIZE	DRAWING NO.	REV
2.25:1	A	564595	A
DO NOT SCALE DRAWING			SHEET 5 OF 10

AFTER MOUNT

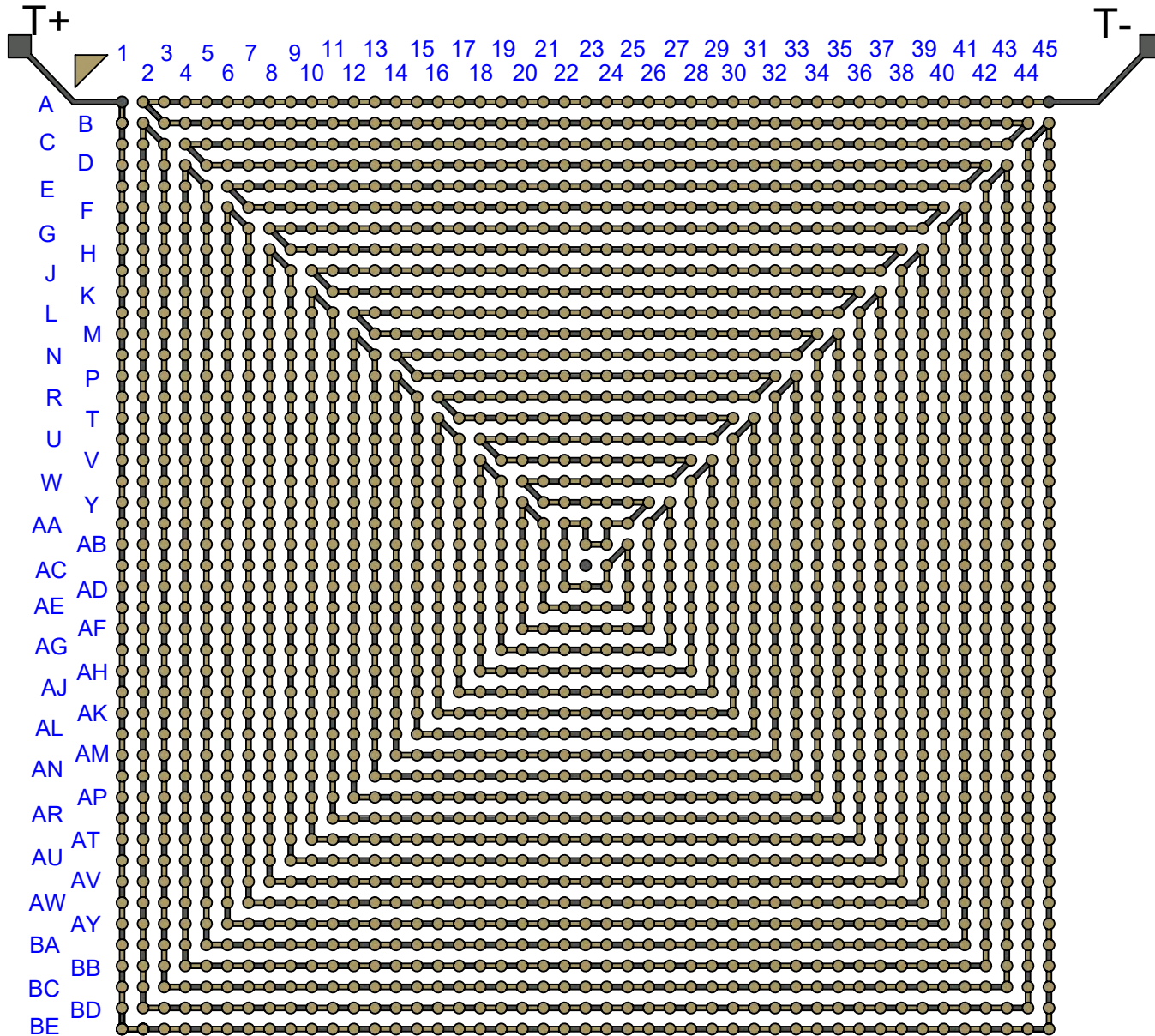

Notes:

- 1) PCB BOARD DIMENSIONS ARE PRESENTED ONLY AS A GUIDELINE. DESIGNERS SHOULD USE THEIR OWN EXPERIENCE WHEN DESIGNING PCB.
- 2) PCB Cu BALL PAD DIAMETER 0.45mm (18 MIL).
- 3) PCB DAISY CHAIN TRACING LINE WIDTH 0.152mm (6 MIL).
- 4) SMD (SOLDER MASK DEFINED) PAD OPENING: 0.33mm (13 MIL).

TopLine®

TITLE		SGBA2025T.65-DC459D DAISY CHAIN DUMMY	
SCALE	SIZE	DRAWING NO.	REV
2.25:1	A	564595	A
DO NOT SCALE DRAWING			SHEET 6 OF 10

MODEL

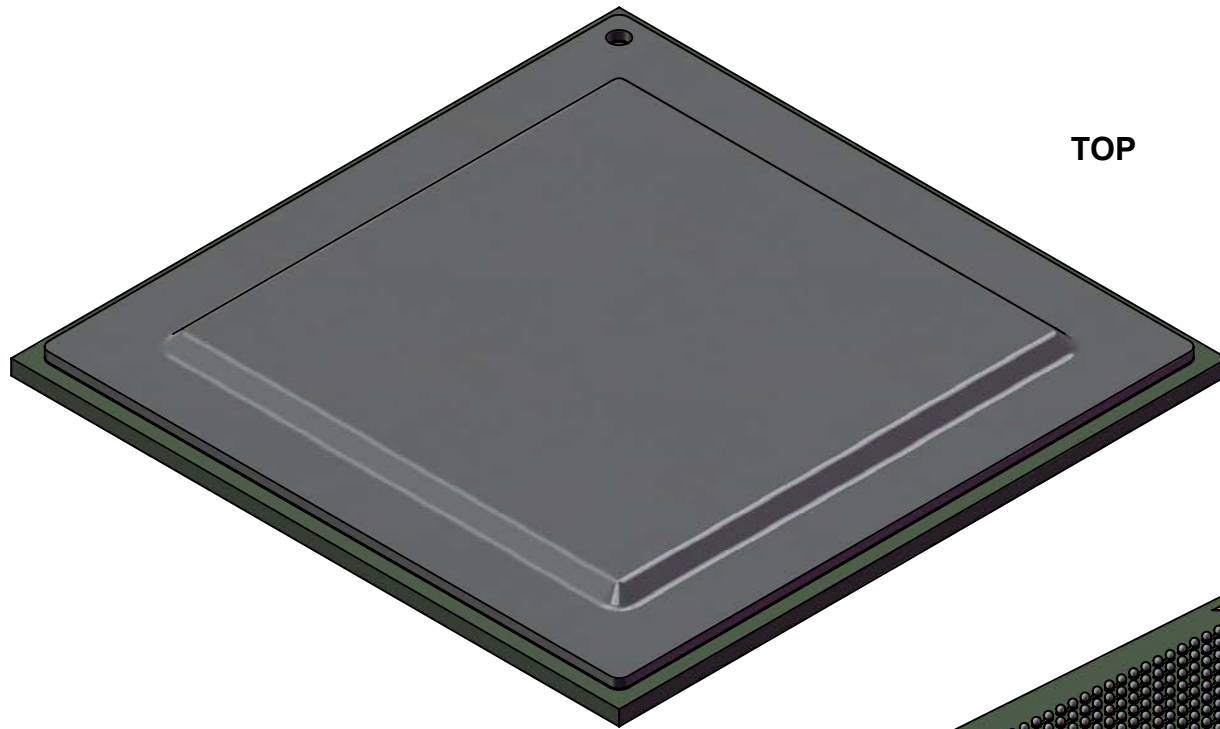

TOP

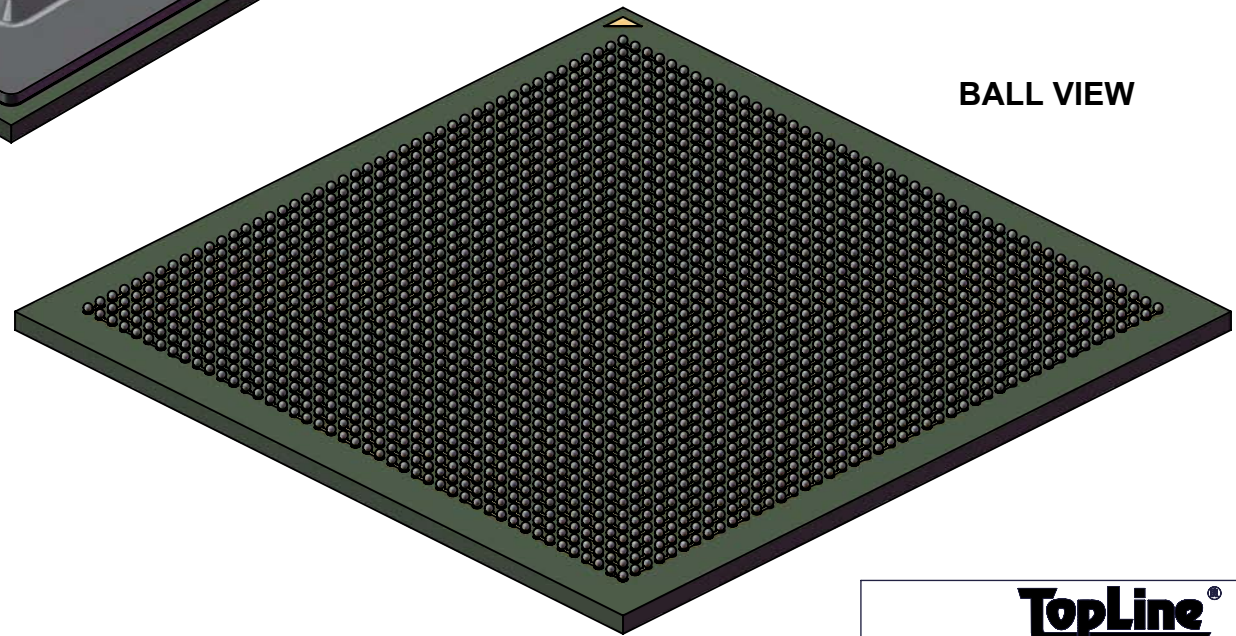

BALL VIEW

TopLine[®]

TITLE SBGA2025T.65-DC459D
DAISY CHAIN DUMMY

SCALE 2.25:1	SIZE A	DRAWING NO. 564595	REV A
-----------------	-----------	-----------------------	----------

DO NOT SCALE DRAWING

SHEET 7 OF 10

HEAT SPREADER

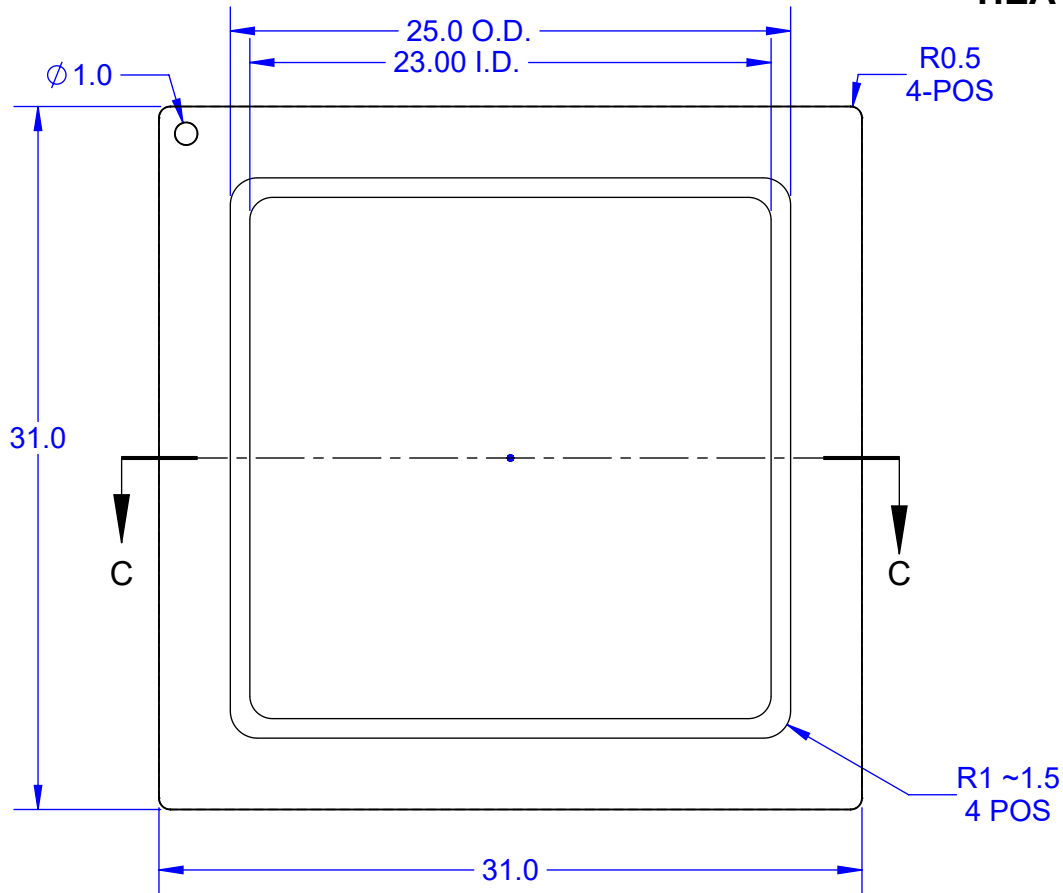

TOP

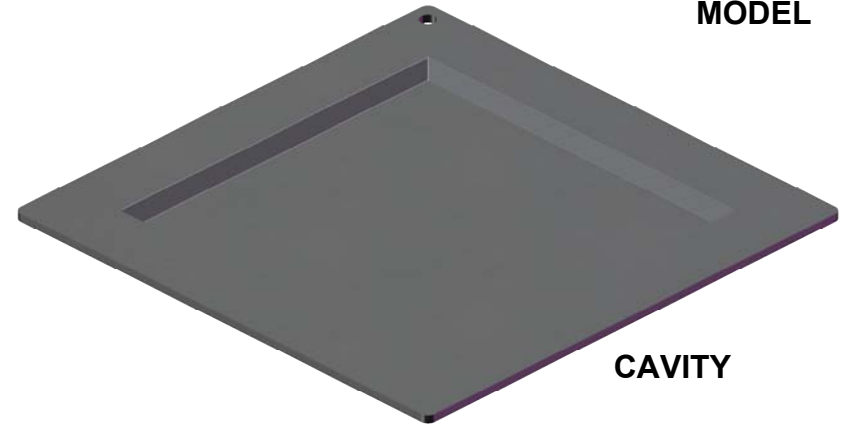

MODEL

CAVITY

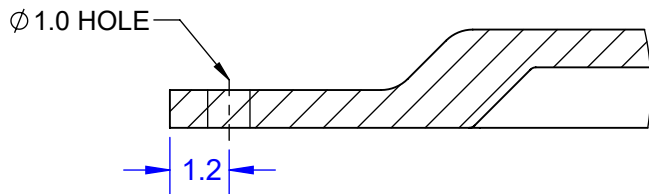

DETAIL D
SCALE 10 : 1

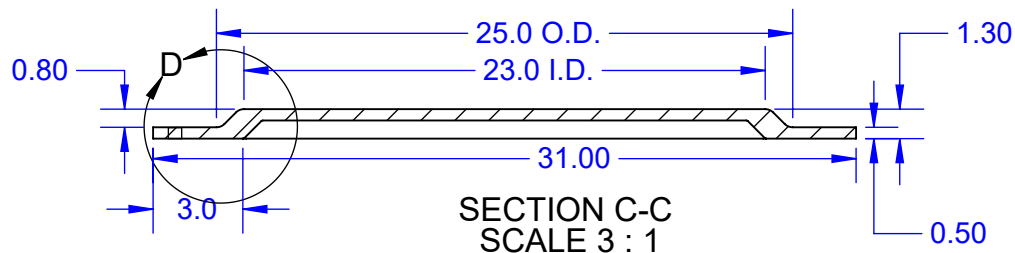

SECTION C-C
SCALE 3 : 1

NOTES:

1. DIMENSION in MM
2. MATERIAL: COPPER ALLOY C1020 OR C1100
HALF HARD, OXYGEN FREE
3. PLATING: NICKEL 5um MIN (SEMI FINISH)

APPROVALS	DATE	TopLine®			
DRAWN T. Au	9/21/2024				
ENG M. Hart	9/21/2024	TITLE H-CAP31A HEAT SPREADER			
MFG		SCALE	SIZE	DRAWING NO.	REV
QA		3:1	A	231710	A
CUST		DO NOT SCALE DRAWING			SHEET 8 OF 10
REVISED					

44 42 40 38 36 34 32 30 28 26 24 22 20 18 16 14 12 10 8 6 4 2
 45 43 41 39 37 35 33 31 29 27 25 23 21 19 17 15 13 11 9 7 5 3 1

A
B
C
D
E
F
G
H
J
K
L
M
N
P
R
T
U
V
W
Y
AA
AB
AC
AD
AE
AF
AG
AH
AJ
AK
AL
AM
AN
AP
AR
AT
AU
AV
AW
AY
BA
BB
BC
BD
BE

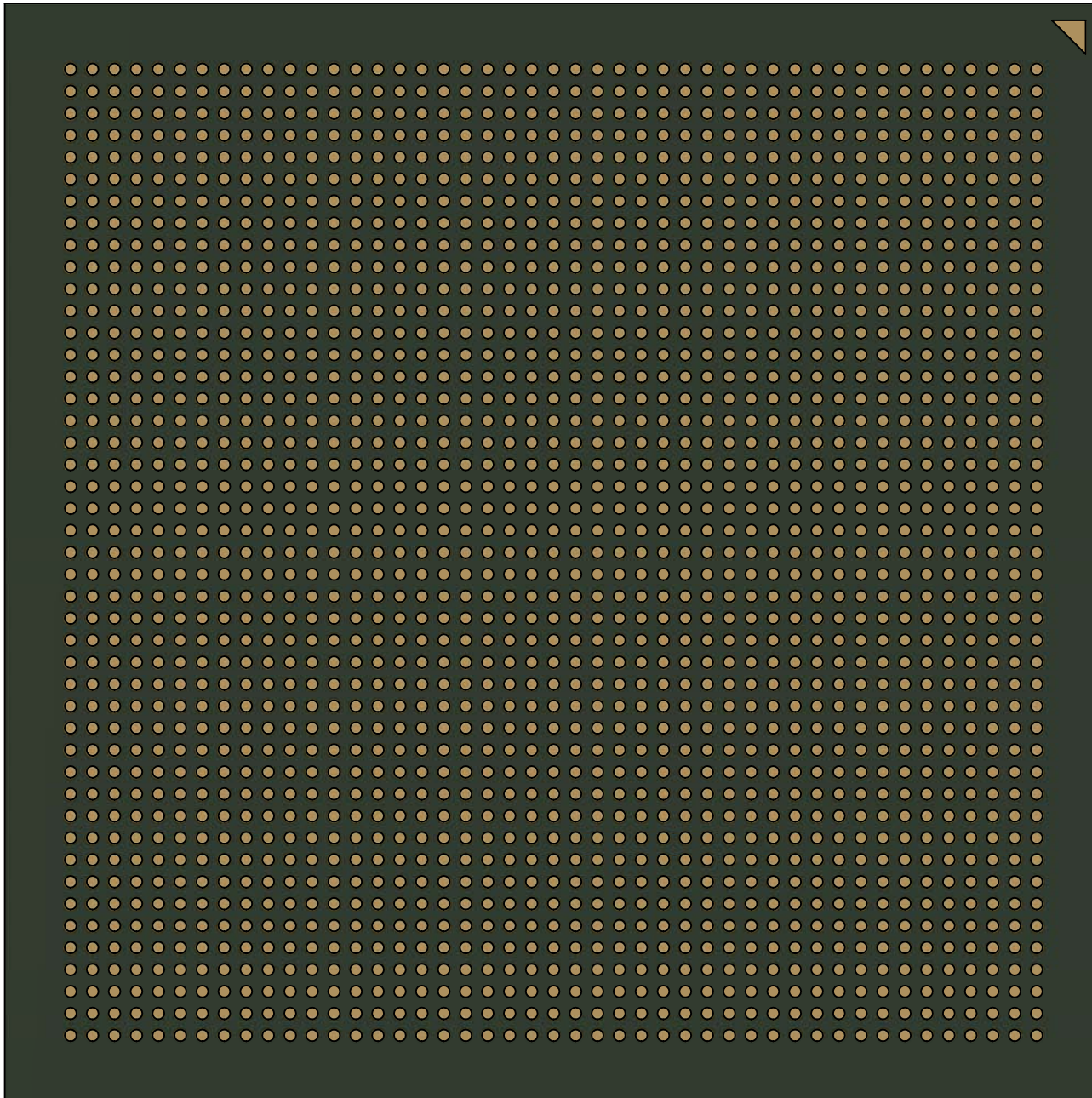

**BOTTOM SOLDER MASK
(BALL VIEW)**

TopLine®			
TITLE SBGA2025T.65-DC459D DAISY CHAIN DUMMY			
SCALE 2.25:1	SIZE A	DRAWING NO. 564595	REV A
DO NOT SCALE DRAWING			SHEET 9 OF 10

STACKUP -SECTION VIEW (NOT TO SCALE)

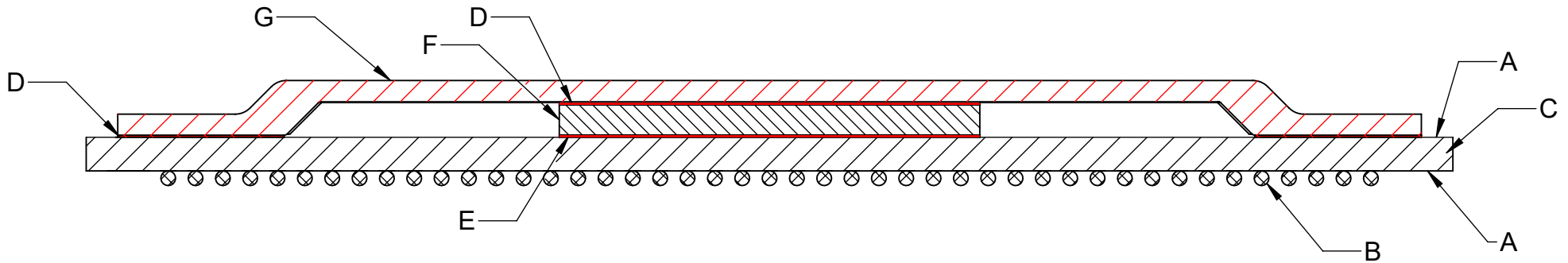

TABLE OF MATERIAL

	DESCRIPTION	MATERIAL
A	COPPER PADS	18um THICK - SOLDER MASK DEFINED PADS (SMD)
B	SOLDER BALL	Sn96.5/Ag3.0/Cu0.5 OR Sn63/Pb37
C	SUBSTRATE	BT MITSUBISHI HL832NS
D	TIM	CORNING SE-4450
E	DIE ATTACH ADHESIVE	HENKEL ABLEBOND 84-3 OR CORNING SE-4450
F	DUMMY DIE	Si WITHOUT BUMPS
G	HEAT SPREADER	C1020 OR C1100 Ni PLATING 5um

TopLine®

TITLE SPGA2025T.65-DC459D
DAISY CHAIN DUMMY

SCALE 3:1	SIZE A	DRAWING NO. 564595	REV A
--------------	-----------	-----------------------	----------

DO NOT SCALE DRAWING

SHEET 10 OF 10